

Introduction

► Feature

- Line pull: 4,309 kg / 9,500 lb synthetic rope first layer
- Synthetic rope: 10mm × 30.5 m (3/8"×100') synthetic rope
- Brake: Patented cone brake holds full load
- Clutch: Turn the T-handle for rapid rope payout
- Control: Handheld pendant switch powers the winch

► Unpacking

- Winch assembly..... 1 pc
- Control box..... 1 pc
- Remote control..... 1 pc
- Synthetic rope with sling hook..... 1 pc
- Hawse fairlead..... 1 pc
- 1.8 m (6') 2 gauge battery lead..... 1 pc

► Read this manual carefully

You should carefully read and understand this manual before operating it. Careless winch operation may result in personal injury hazards or property damage.

Installation

Before using the winch, make sure all electrical components have no corrosion or damaged; the environment should be clear and dry.

► Winch and hawse fairlead mountings

- It is very important that the winch will be mounted on a flat and hard surface of mounting channel in order to make sure the motor, drum and gearbox housing are aligned correctly.
- Hawse fairlead does not mount to the winch directly.

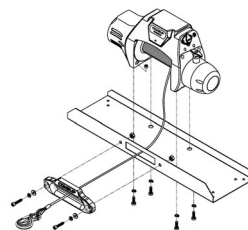

- The synthetic rope shall be wound in an under-wound orientation only.
- Four (4) M10 x 1.50 pitch 10.9 grade with 63.8 N-m torque settings (maximum) high tensile steel bolts must be used in order to sustain the loads imposed on the winch mounting.
- Two (2) M10 x 1.50 pitch stainless steel bolts must be used for fastening the hawse fairlead into the mounting channel.

► Wiring Diagram

- Connect thermal sensor harness plug, control ground, and cable A/F1/F2 to the motor.
- Attach the ground lead firmly to the negative (-) battery terminal and power lead to the positive (+) battery terminal. The voltage drop for the winch motor must not exceed 10% of the nominal voltage of 12V DC.

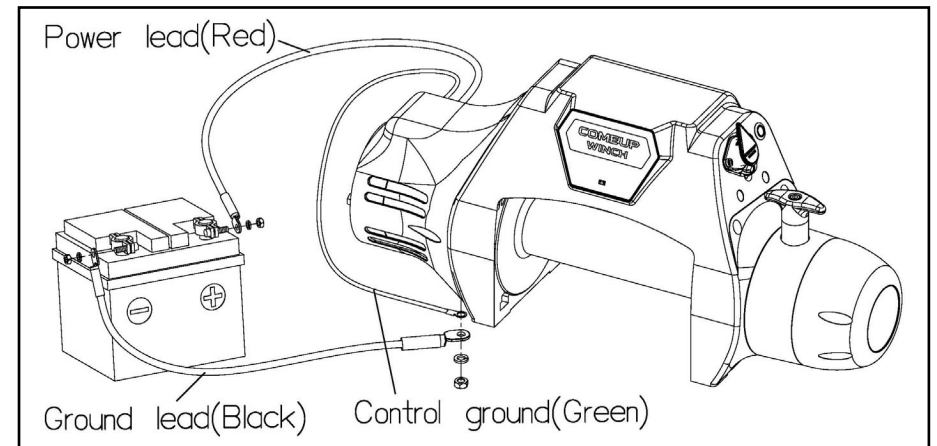

► Nut fastening for motor & contactor

1. Holding the lower nut on the stub and fastening the upper nut clockwise.
2. The torque setting for nut is 14 N-m/124 lb-in.

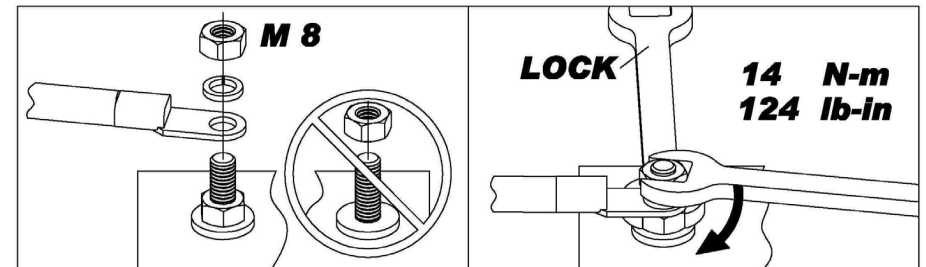

Warning

- The winch is not intended to be used in any manner for the movement or lifting of personnel.
- The rated line pull shown is based on the first layer of rope on the drum.
- The rope winding on the drum shall remain 10 wraps from the drum to support the rated load.
- Manufacturer is not responsible for the results of misuse, misapplication, faulty installation or abuse of synthetic rope in any way.

Parts List

Item No.	Description	Part No.	Qty
1	Waterproof motor w/housing 12V	883544	1
2	Tie bar kit	883132	2
3	Motor coupling	880005	1
4	Drum bushing	880006	2
5	Drum kit	881521	1
6	Gearbox support rack	882523	1
7	Grounding lead	880009	1
8	Synthetic rope	883248	1
9	1 st shaft	880011	1
10	3 rd ring gear kit	880114	1
11	3 rd stage carrier	880115	1
12	2 nd stage carrier	880116	1
13	1 st stage carrier	880117	1
14	1 st & 2 nd ring gear	880118	1
15	1 st pinion	880119	1
16	Clutch kit	881564	1
17	Gear box kit	882524	1
18	Cone brake disc kit	880122	1
19	Brake cover kit	882525	1
20	Hawse fairlead	883410	1
21	Mounting hardware	880125	1
22	Remote control	880126	1
23	Handsaver strap	880026	1
24	Bridge Control box 12V	882681	1
24-1	Remote socket kit 12V	882718	1
24-2	Control pack 12V	882683	1
24-2-1	Central module kit 12V	882682	1
24-3	PC board kit	882684	1
24-4	Cutout switch	882693	1
25	Brake clutch base	881100	1
26	Motor side cover	882680	1
27	Sling hook	882477	1

Winch Assembly

