

COMEUP WINCH

Model: **GTD-3300**

PN: 753140 12V
753150 24V

Introduction

► Feature

- Line lifting: 1,500 kg / 3,300 lb wire rope first layer
- Wire rope: 9.5 mm × 26.5 m (3/8" × 87') galvanized aircraft A7 × 19
- Brake: Both Mechanical cone brake and permanent motor dynamic brakes
- Control: Handheld pendant switch powers the hoist

► Unpacking

- Hoist assembly..... 1 pc
- Control box..... 1 pc
- Remote control..... 1 pc
- Wire rope with clevis hook..... 1 pc

► Read this manual carefully

You should carefully read and understand this manual before operating it. Careless hoist operation may result in personal injury hazards or property damage.

► Information requesting or parts ordering

Please specify the following information:

- Hoist PN
- Serial number
- Quantity for each part
- Part description
- Replacement part number

Installation

Before using the hoist, make sure all electrical components have no corrosion or damaged; the environment should be clear and dry.

► Hoist mounting

Eight (8) M12 x 30L 8.8 grade with 76 N-m torque settings (maximum) high tensile steel bolts must be used in order to sustain the loads imposed on the winch mounting.

► Wire Rope Replacement

- Feed the end of the wire rope into No. 1 anchor hole in the drum and wind about 1/4 wrap of rope on the drum. Insert the wire rope into No. 2 hole and tighten the set screw securely.
- Make sure the first layer of wire rope is tight and maintain a freeboard at least 1.5 x rope diameter.
- Wire rope shall be wound in an under-wound orientation only.
- To compensate for uneven spooling and the decrease in line pull capacity as the drum fills up, use as short a wire rope as practical.

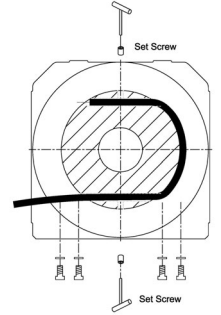

► Wiring Diagram

- Connect positive/negative terminal cables to the winch motor.
- Attach the ground lead firmly to the negative (-) battery terminal and power lead to the positive (+) battery terminal. The voltage drop for the winch motor must not exceed 10% of the nominal voltage of 12/24VDC.

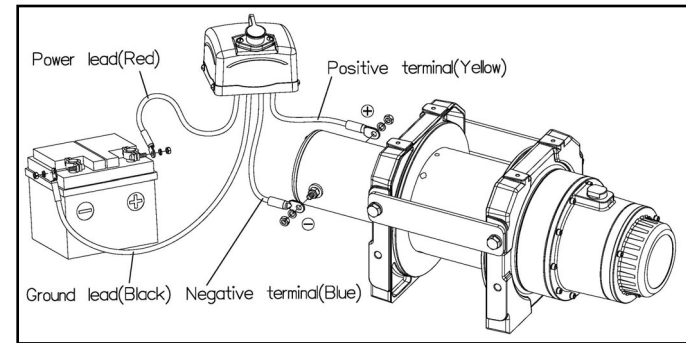

► Nut fastening for motor & contactor

- Holding the lower nut on the stub and fastening the upper nut clockwise.
- The torque setting for nut is 6 N-m / 58 lb-in. (Terminal material copper)

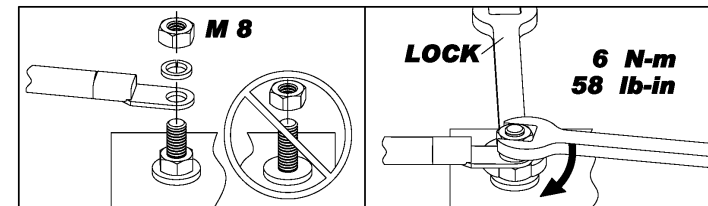

Warning

- The operator shall always work in compliance with the operating instructions.
- Overload shall be forbidden and overload protection shall be required.
- Ban on transporting persons and excessive inching shall be avoided.
- Don't try to move obstructed loads and side-pull of load is not allowed
- The rope winding on the drum shall remain 5 wraps from the drum.

Performance Data

Lifting Load	Line Speed				Amp. Draw	Percentage Duty Cycle min / 10 min
	mpm		fpm			
kg / lb	12V	24V	12V	24V	12V / 24V	12V / 24V
No load	4.8	6.0	15.7	19.7	60 / 40	Cont.
262 / 600	4.4	5.7	14.4	18.7	70 / 50	7.0
544 / 1,200	4.3	5.5	14.1	18.0	100 / 70	4.5
816 / 1,800	4.1	5.2	13.5	17.4	125 / 85	3.0
1,089 / 2,400	3.9	5.0	12.8	15.1	140 / 95	2.5
1,134 / 2,500	3.8	4.7	12.5	15.4	165 / 110	2.0
1,500 / 3,300	3.6	4.4	11.8	14.4	200 / 130	1.5

Parts List

Item No.	Description	Part No.	Qty
1	Motor 12V	884320	1
	Motor 24V	884321	
2	Tie bar kit	884077	2
4	Motor coupling	880047	1
5	Drum bushing	880048	2
6	Drum kit	884078	1
7	Gearbox support rack	881597	1
8	1 st shaft	884079	1
9	3 rd ring gear kit	882436	1
10	3 rd stage carrier kit	881944	1
11	2 nd stage carrier kit	881943	1
12	1 st stage carrier kit	880107	1
13	Retaining ring	880058	1
14	1 st & 2 nd ring gear	880059	1
15	1 st pinion kit	880060	1
16	Tap screw	881423	1
17	Gear box kit	882437	1
18	Brake base	882438	1
19	Cone brake disc kit	882529	1
20	Brake clutch base	883241	1
21	Brake cover kit	882470	1
22	Mounting hardware	881598	1
23	Remote control	880025	1
24	Control box 12V	884081	1
	Control box 24V	884082	
24-1	Remote socket kit	880029	1
24-2	Control pack 12V	884085	1
	Control pack 24V	884086	
25	Wire rope	884080	1
26	Clevis hook	881996	1

Hoist Assembly

