

Introduction

► Feature

- Line pull: 5,443 kg / 12,000 lb wire rope first layer
- Wire rope: 10.3 mm × 25.5 m (13/32" × 83.7') galvanized aircraft A7 × 19
- Brake: Exclusive brake design with No. 37C device
- Clutch: Turn the mechanism lever for rapid wire rope payout
- Control: Handheld pendant switch powers the winch

► Unpacking

- Winch assembly..... 1 pc
- Control box..... 1 pc
- Remote control..... 1 pc
- Wire rope with Clevis hook..... 1 pc
- Roller fairlead..... 1 pc
- 1.8 m (6') 2 gauge battery lead..... 1 pc

► Read this manual carefully

You should carefully read and understand this manual before operating it. Careless winch operation may result in personal injury hazards or property damage.

Installation

Before using the winch, make sure all electrical components have no corrosion or damaged; the environment should be clear and dry.

► Winch and roller fairlead mountings

- It is very important that the winch will be mounted on a flat and hard surface of mounting channel in order to make sure the motor, drum and gearbox housing are aligned correctly.

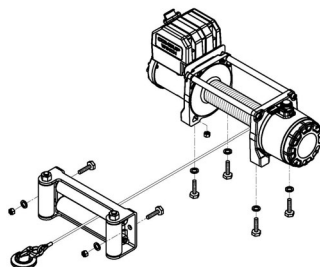

- Roller fairlead does not mount to the winch directly.
- The wire rope shall be wound in an under-wound orientation only.
- Four (4) M10 x 1.50 pitch 8.8 grade with 44 N-m torque settings (maximum) high tensile steel bolts must be used in order to sustain the loads imposed on the winch mounting.
- Two (2) M10 x 1.50 pitch 8.8 grade with 44 N-m torque settings (maximum) high tensile steel bolts must be used for fastening the roller fairlead into the mounting channel.

► Wiring Diagram

- Connect control ground to the motor.
- Attach the ground lead firmly to the negative (-) battery terminal and power lead to the positive (+) battery terminal. The voltage drop for the winch motor must not exceed 10% of the nominal voltage of 12V DC.

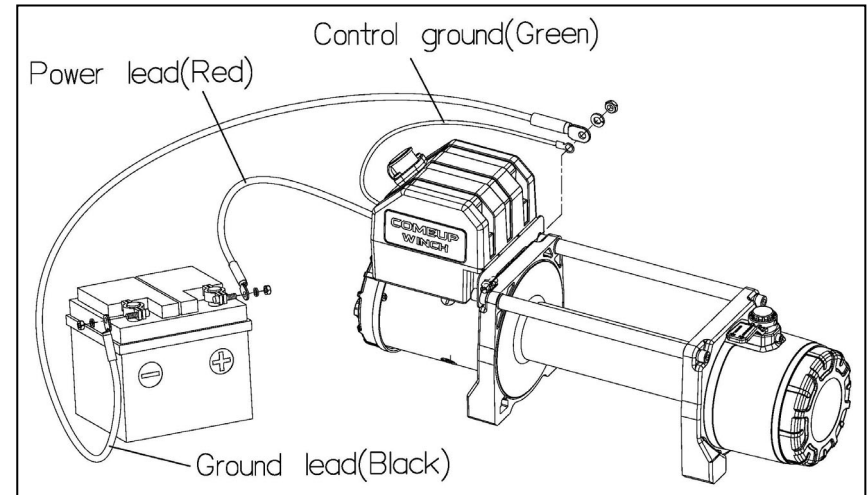

► Nut fastening for motor & contactor

1. Holding the lower nut on the stub and fastening the upper nut clockwise.
2. The torque setting for nut is 14 N-m/124 lb-in.

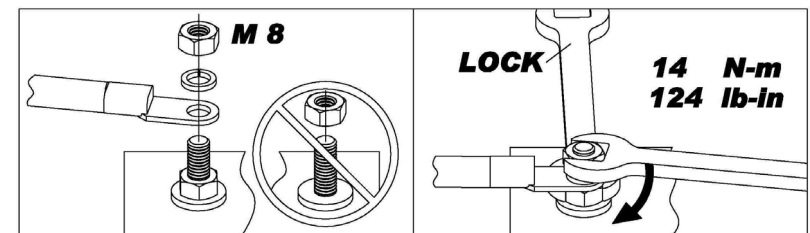

Warning

- The winch is not intended to be used in any manner for the movement or lifting of personnel.
- The rated line pull shown is based on the first layer of rope on the drum.
- The rope winding on the drum shall remain 5 wraps from the drum.

Parts List

Item No.	Description	Part No.	Qty
1	Waterproof motor w/housing 12V	883203	1
2	Tie bar kit	883641	2
3	Brake clutch base kit	883206	1
4	Drum bushing	880006	2
5	Drum kit	883207	1
6	Cone brake disc kit	883208	1
7	Gearbox support rack	883209	1
8	Grounding lead	883210	1
9	Wire rope	883213	1
10	1 st shaft	883214	1
11	ring gear kit	883215	1
12	3 rd stage carrier	883216	1
13	2 nd stage carrier	883217	1
14	1 st stage carrier	883218	1
15	1 st pinion	883219	1
16	Clutch kit	883220	1
17	Gear box kit	883221	1
18	Roller fairlead	883222	1
19	Mounting hardware	883223	1
20	Remote control	880025	1
21	Handsaver strap	880026	1
22	Control box 12V	883638	1
22-1	Remote socket kit	883235	1
22-2	Control pack 12V	883640	1
23	Clevis hook	881996	1

Winch Assembly

