

### Introduction

#### ► Feature

- Line pull: 3,630 kg / 8,000 lb synthetic rope first layer
- Synthetic rope: 10 mm × 30.5 m (3/8"×100') synthetic rope
- Brake: Patented cone brake holds full load
- Clutch: Turn the T-handle for rapid rope payout
- Control: Handheld pendant switch powers the winch

#### ► Unpacking

- Winch assembly..... 1 pc
- Control box..... 1 pc
- Remote control..... 1 pc
- Synthetic rope with sling hook..... 1 pc
- Hawse fairlead..... 1 pc
- 1.8 m (6') 2 gauge battery lead..... 1 pc

#### ► Read this manual carefully

You should carefully read and understand this manual before operating it. Careless winch operation may result in personal injury hazards or property damage.

### Installation

Before using the winch, make sure all electrical components have no corrosion or damaged; the environment should be clear and dry.

#### ► Winch and hawse fairlead mountings

- It is very important that the winch will be mounted on a flat and hard surface of mounting channel in order to make sure the motor, drum and gearbox housing are aligned correctly.
- Hawse fairlead does not mount to the winch directly

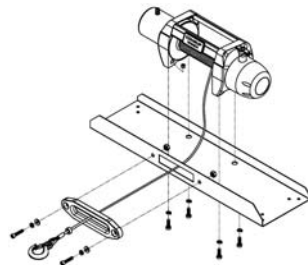

- The synthetic rope shall be wound in an under-wound orientation only
- Four (4) M10 x 1.50 pitch 10.9 grade with 63.8 N-m torque settings (Maximum) high tensile steel bolts must be used in order to sustain the loads imposed on the winch mounting.
- Two (2) M10 x 1.50 pitch stainless steel bolts must be used for fastening the hawse fairlead into the mounting channel.

#### ► Wiring Diagram

Attach the black lead firmly to the negative (-) battery terminal and red lead to the positive (+) battery terminal. The voltage drop for the winch motor must not exceed 10% of the nominal voltage of 12V DC.

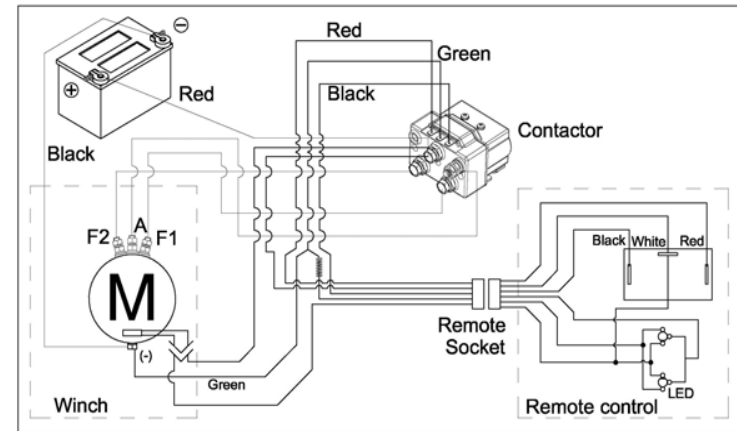

#### ► Nut fastening for motor & contactor

1. Holding the lower nut on the stub and fastening the upper nut clockwise.
2. The torque setting for nut is 14 N-m/124 lb-in.

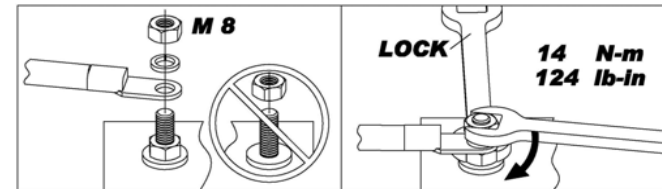

### Warning

- The winch is not intended to be used in any manner for the movement or lifting of personnel.
- The rated line pull shown is based on the first layer of rope on the drum.
- The rope winding on the drum shall remain 10 wraps from the drum to support the rated load.
- Manufacturer is not responsible for the results of misuse, misapplication, faulty installation or abuse of synthetic rope in any way.

## Parts List

Item No.	Description	Part No.	Qty
1	Waterproof motor w/housing 12V	883013	1
2	Forward tie bar kit	882521	1
3	Reverse tie bar kit	882522	1
4	Motor coupling	880005	1
5	Drum bushing	880006	2
6	Drum kit	881521	1
7	Gearbox support rack	882523	1
8	Grounding lead	880009	1
9	Synthetic rope	883248	1
10	1 <sup>st</sup> shaft	880011	1
11	3 <sup>rd</sup> ring gear kit	880114	1
12	3 <sup>rd</sup> stage carrier	880115	1
13	2 <sup>nd</sup> stage carrier	883015	1
14	1 <sup>st</sup> stage carrier	883016	1
15	1 <sup>st</sup> & 2 <sup>nd</sup> ring gear	880118	1
16	1 <sup>st</sup> pinion	883017	1
17	Clutch kit	881564	1
18	Gear box kit	882524	1
19	Cone brake disc kit	880122	1
20	Brake clutch base	881100	1
21	Brake cover kit	883018	1
22	Hawse fairlead	881061	1
	Hawse fairlead (for 296065/296061)	883067	1
23	Mounting hardware	880024	1
24	Remote control	880126	1
25	Handsaver strap	880026	1
26	Control box 12V	881164	1
	Control box 12V (for 296065/296061)	883070	1
26-1	Remote socket kit 12V	881373	1
26-2	Control pack 12V	881400	1
	Control pack 12V (for 296065/296061)	883071	1
27	Sling hook	882477	1
28	Clamp	882160	2

## Winch Assembly

