

Introduction

► Feature

- Line pull: 9,072 kg / 20,000 lb synthetic rope first layer
- Wire rope: 14 mm × 16.7 m (9/16"×55') synthetic rope
- Brake: Patented cone brake holds full load
- Clutch: Turn the T-handle for rapid wire rope payout
- Control: Handheld pendant switch powers the winch

► Unpacking

- Winch assembly..... 1 pc
- Potted control box..... 1 pc
- Remote control..... 1 pc
- Synthetic rope with sling hook..... 1 pc
- Hawse fairlead..... 1 pc
- 1.8 m (6') 2 gauge battery lead..... 1 pc

► Read this manual carefully

You should carefully read and understand this manual before operating it. Careless winch operation may result in personal injury hazards or property damage.

Installation

Before using the winch, make sure all electrical components have no corrosion or damaged; the environment should be clear and dry.

► Winch and hawse fairlead mountings

- It is very important that the winch will be mounted on a flat and hard surface of mounting channel in order to make sure the motor, drum and gearbox housing are aligned correctly.
- Hawse fairlead does not mount to the winch directly.
- The synthetic rope shall be wound in an under-wound orientation only.

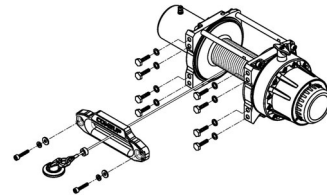

- Eight (8) M12 x 1.75 pitch 12.9 grade w/137 N-m torque setting (maximum) high tensile steel bolts must be used in order to sustain the loads imposed on the winch mounting.
- Two (2) M10 x 1.50 pitch stainless steel bolts must be used for fastening the hawse fairlead into the mounting channel.

► Wiring Diagram

- Connect thermal sensor harness plug, control ground, and cable A/F1/F2 to the motor.
- Attach the ground lead firmly to the negative (-) battery terminal and power lead to the positive (+) battery terminal. The voltage drop for the winch motor must not exceed 10% of the nominal voltage of 12V DC.

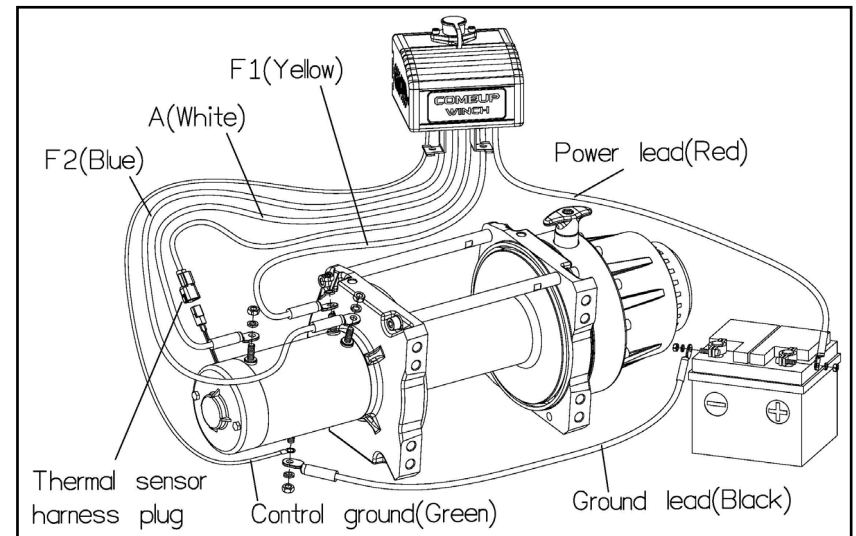

► Nut fastening for motor & contactor

1. Holding the lower nut on the stub and fastening the upper nut clockwise.
2. The torque setting for nut is 14 N-m/124 lb-in.

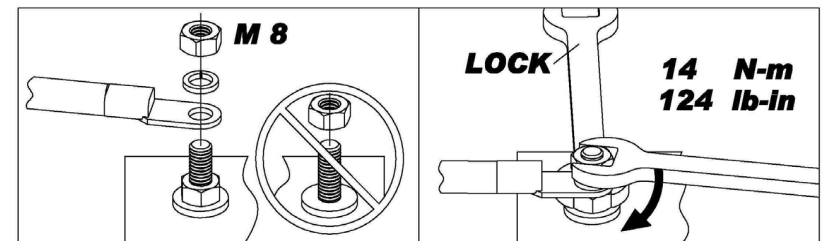

Warning

- The winch is not intended to be used in any manner for the movement or lifting of personnel.
- The rated line pull shown is based on the first layer of rope on the drum.
- The rope winding on the drum shall remain 10 wraps from the drum.
- Manufacturer is not responsible for the results of misuse, misapplication, faulty installation or abuse of synthetic rope in any way.

Parts List

Item No.	Description	Part No.	Qty
1	Waterproof motor w/housing 12V	883674	1
2	Tie bar kit	882856	3
3	Motor coupling	882201	1
4	Drum bushing	880048	1
5	Drum kit	882202	1
6	Drum bushing	882204	1
7	Gearbox support rack	882900	1
8	Grounding lead	880009	1
9	Synthetic rope	883676	1
10	Sling hook	883677	1
11	1 st shaft	882206	1
12	3 rd ring gear kit	882208	1
13	3 rd stage carrier	882210	1
14	2 nd stage carrier	882211	1
15	1 st stage carrier	882212	1
16	1 st pinion	882213	1
17	Clutch kit	882214	1
18	Gear box kit	882215	1
19	Cone brake disc kit	882216	1
20	Brake clutch base	882217	1
21	Brake cover kit	882423	1
22	Hawse fairlead	883410	1
23	Mounting hardware	882854	1
24	Remote control	880126	1
25	Handsaver strap	880026	1
26	Control box 12V	881164	1
26-1	Remote socket kit 12V	881373	1
26-2	Control pack 12V	881400	1

Winch Assembly

