

Introduction

► Feature

- Lifting capacity: 300 kg wire rope top layer
- Lifting height: 29 m
- Lifting speed: 16 – 25 m/min
- Motor output: 2.3kw x 11A at 220-240V
- Brake: Electromagnetic and mechanical ratchets
- Control: Pendant switch powers the winch

► Unpacking

- Winch assembly 1pc
- Wire rope 6 mm x 30 m 1pc
- Weight hook CHW-0031 1pc
- Pendant switch PB-417 w/cord 2.0 mm² x 6C x 10m 1pc

► Read this manual carefully

You should carefully read and understand this manual before operating it. Careless winch operation may result in personal injury hazards or property damage.

► Information requesting or parts ordering

Please specify the followings information:

- Winch PN
- Serial number
- Part description
- Replacement part number
- Quantity for each part

Installation

Before using the winch, make sure all electrical components have no corrosion or damaged; the environment should be clear and dry.

► Wire rope replacement

- Insert the wire rope into the hole of drum and fix it with a P. T. screw, then press the "UP" button of switch for rotate the drum in the lifting direction.
- Wind the wire rope accurately around the drum, and an irregular winding will cause the load to be swing, thus damaging the wire and reducing the life of winch.
- When replacing, according to the following procedures.
 - *Pull out a R-dowel "D" from the round head pin "C".
 - *Pull out a round head pin "C" from hook body "A".
 - *Put a wire rope "B" into the hole of hook body "A", and insert a round head pin "C" through wire rope and fixture hole of hook body "A".
 - *Insert a R-dowel "D" into the hole of round head pin "C".

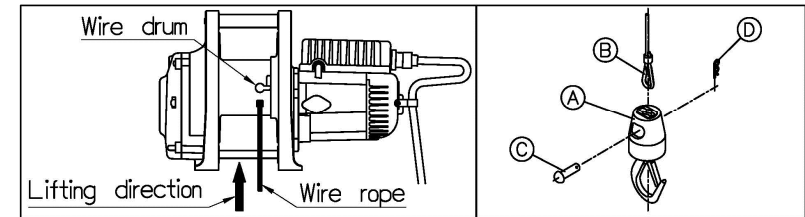

► Wiring Diagram

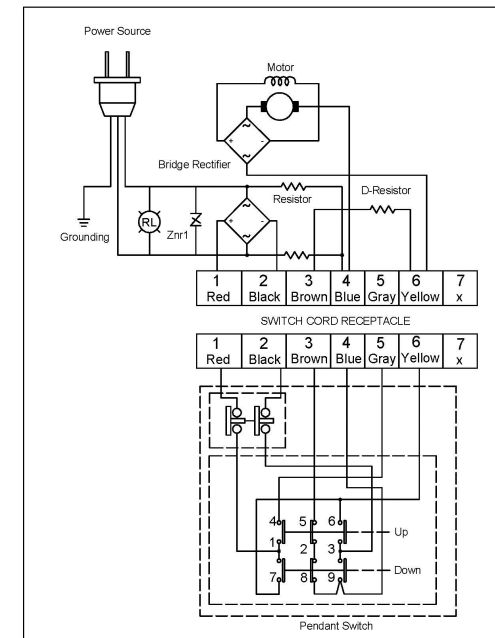

Warning

- The winch is not intended to be used in any manner for the movement or lifting of personnel.
- The lifting capacity shown is based on the top layer of rope on the drum.
- The rope winding on the drum shall remain 5 wraps from the drum.

Parts List

Item No.	Description	Part No.	Qty
1	Protection cover kit	880581	1
2	Gearbox rear cover kit	880582	1
3	Ratchet stopper kit	880494	2
4	2 nd shaft	880583	1
5	3 rd gear kit	880584	1
6	Brake kit	881534	1
7	Tie bar kit	880552	1
8	Tie bar kit A	880553	2
9	Wire rope	880383	1
10	Weight hook	880384	1
11	Gearbox support rack kit	880590	1
12	Output shaft kit	880556	1
13	Drum kit	881518	1
14	Motor coupling kit	881515	1
15	Motor support rack kit	880558	1
16	Torque shaft kit	881535	1
17	Motor bracket kit	880595	1
18	Cooling ring	880596	1
19	Armature winding, 220/230V	880603	1
	Armature winding, 240V	880604	
20	Armature core, 220/230V	880978	1
	Armature core, 240V	880979	
21	Motor housing kit	880599	1
22	Carbon brush lead	880600	2
23	Carbon brush	880601	2
24	Terminal upper cover kit	882415	1
25	Control panel	882416	1
26	Remote control, PB-417	883146	1

Winch Assembly

