

Compact Winch Model: CWS-80

PN: 422390 220V
422386 220V
422915 230V

Introduction

► Feature

- Lifting capacity: 80 kg wire rope top layer
- Lifting height: 23 m
- Lifting speed: 18 – 30 m/min
- Brake: Electromagnetic and mechanical ratchet
- Limit protection: Lifting and lowering limiters
- Control: Pendant switch powers the winch

► Unpacking

- Winch assembly 1pc
- Wire rope 4 mm x 24 m 1pc
- Wight hook CHW-0032 1pc
- Power lead 1.5 mm² x 3C x 5 m and plug 1pc
- Pendant switch CPB-313 w/cord 1.25mm² x 6C x 10m 1pc

► Read this manual carefully

You should carefully read and understand this manual before operating it. Careless winch operation may result in personal injury hazards or property damage.

► Information requesting or parts ordering

Please specify the followings information:

- Winch PN
- Serial number
- Part description
- Replacement part number
- Quantity for each part

Installation

Before using the winch, make sure all electrical components have no corrosion or damaged; the environment should be clear and dry.

► Wire rope replacement

- Put a new wire rope through the hole of the round plate of weight hook.
- Insert a sleeve pin through the thimble of wire rope.
- Insert a pin through the sleeve pin and bent it by a pliers.
- Let a new wire rope w/clamp through the limit lever and insert it into the hole of the drum.
- Put a P.T. screw into the hole of the drum and tighten it by a hexagon wrench.
- Press the ↑ button to rotate the drum in the lifting direction.
- An uneven winding of wire rope may cause the load to be swing, thus damaging the rope and reducing its life.

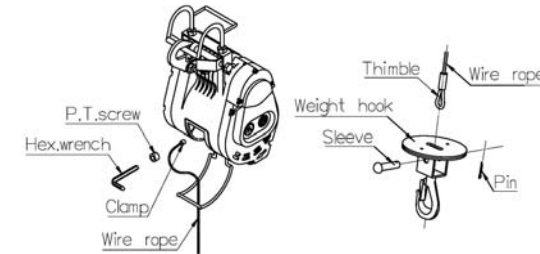

► Wiring Diagram

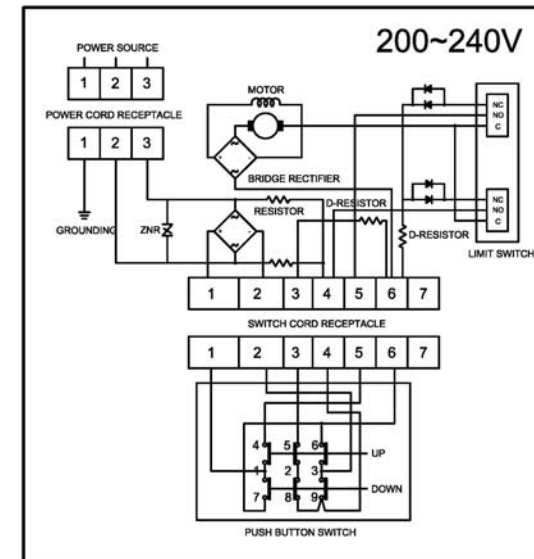

Warning

- The winch is not intended to be used in any manner for the movement or lifting of personnel.
- The lifting capacity shown is based on the top layer of rope on the drum.
- The rope winding on the drum shall remain 5 wraps from the drum.

Parts List

Item No.	Description	Part No.	Qty
1	Gearbox rear cover kit	880565	1
2	Ratchet stopper kit	880506	1
3	1 st gear kit	881566	1
4	Brake kit	881567	1
5	3 rd gear kit	880469	1
6	Gear box kit	881568	1
7	Hanger kit	880471	1
8	Carbon brush holder	880472	1
9	Carbon brush 110V~240V	880473	2
10	Over-winding bracket kit	880474	1
11	Wire rope	880449	1
12	Weight hook CHW-0032	880475	1
13	Armature core	880971	1
14	Cooling cover	881500	1
15	Armature winding	880489	1
16	Motor rear cover kit	880477	1
17	Reverse winding shaft kit	881256	1
18	Output shaft kit	881569	1
19	Drum kit	881570	1
20	Control panel 220~240V	880482	1
20-1	D type resistor 220~240V	881502	2
20-2	Limit switch	881503	2
20-3	Diode	881504	2
21	Rubber packing	880483	1
22	Electric cover kit	880484	1
23	Power lead w/3 round pins plug	880492	1
24	Remote control , CPB-313	880486	1

Winch Assembly

